

**NOTES:**

1. MULTIPLE BIKE RACK SHALL BE "FLO" MULTI-RACK FROM LANDSCAPE FORMS OR APPROVED EQUAL.
2. LOCATE BIKE RACKS INCLUDING SPACE FOR PARKED BIKES OUTSIDE PEDESTRIAN PATH OF TRAVEL, SEE PLAN VIEW FOR CLEARANCES.
3. INSTALL MULTIPLE BIKE RACK LEVEL AND PLUMB ACCORDING TO MANUFACTURER'S RECOMMENDED METHOD AND HARDWARE.
4. APPLIES TO ALL STREETSCAPE TYPES.
5. BIKE RACKS SHALL HAVE ANTI-GRAFFITI COATING FINISH.
6. ALTERNATIVE BIKE RACKS MAY BE APPROVED BY THE CITY ENGINEER. BIKE RACKS SHALL MEET THE ESSETIAL PERFORMANCE REQUIREMENTS AS DEFINED BY THE ASSOCIATION OF PEDESTRIAN AND BICYCLE PROFESSIONALS (APBP) ESSENTIALS OF BIKE PARKING.

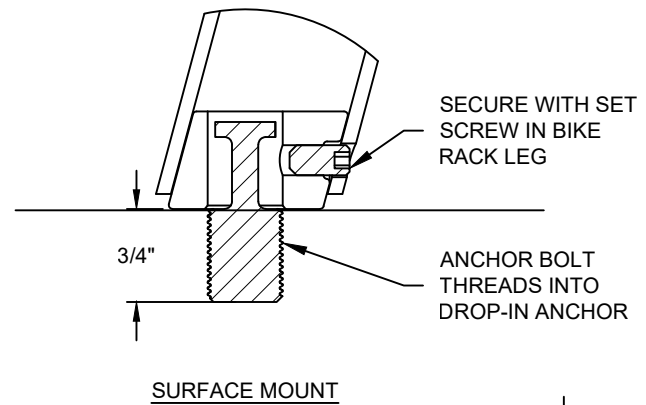

SIDE ELEVATION

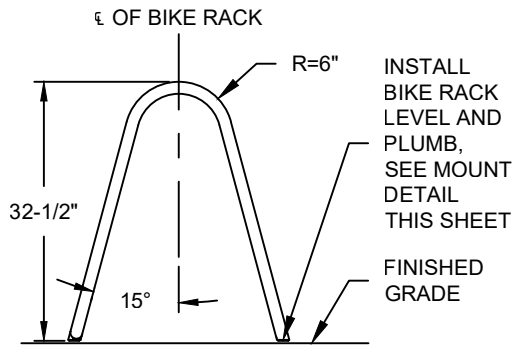
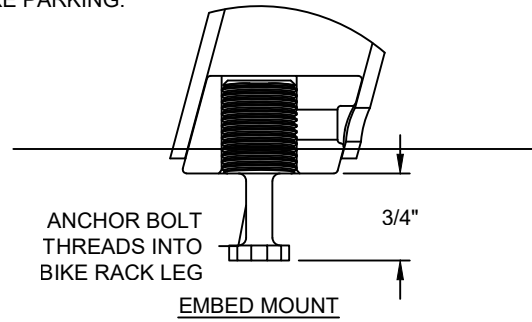
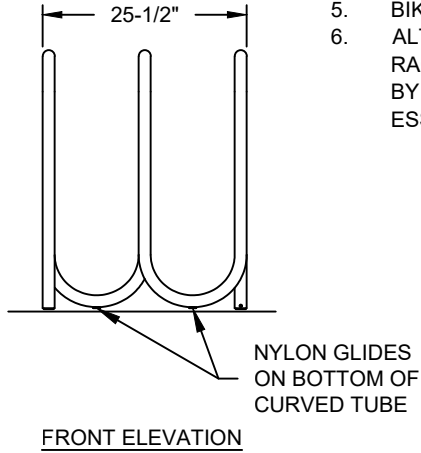
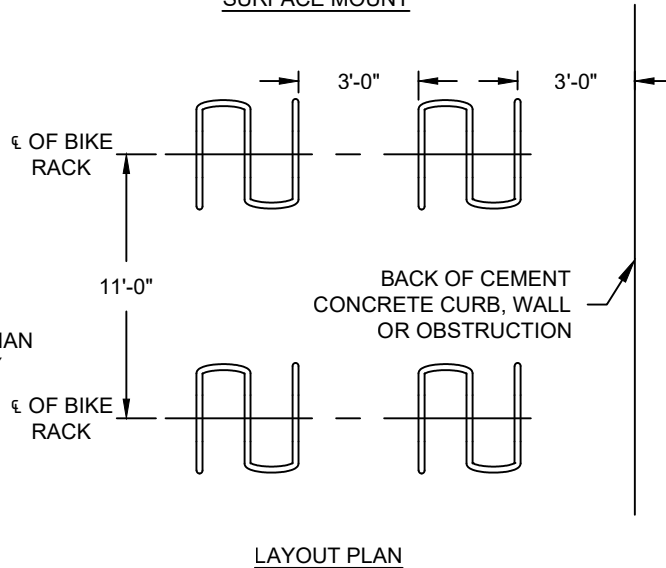
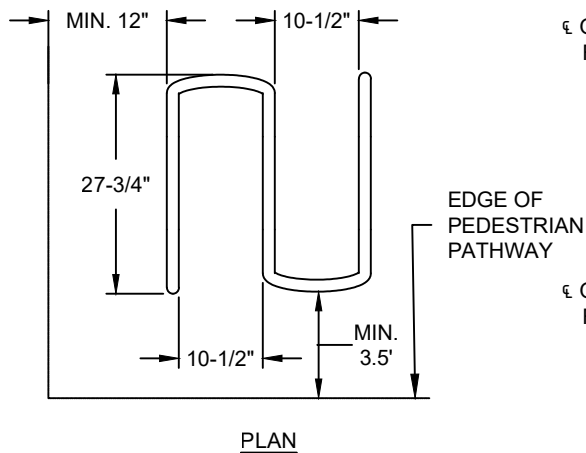

DRAWING NUMBER	CC-SID-14
SCALE	NONE
REVISION DATE	03/22
DEPARTMENT	PW